

Sharpstown

CIVIC ASSOCIATION newsletter

The Official Publication of the Sharpstown Civic Association

Volume 50, Issue 1

Jan/Feb 2026

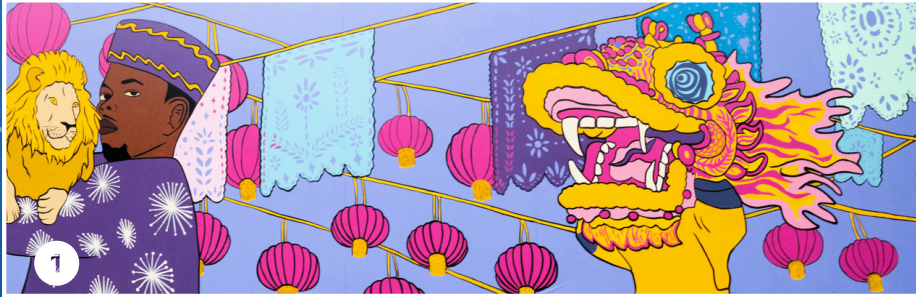

*PlaceMAKE Precinct 4 Presents:
Southwest Houston Murals, Jan. 30*

- 1 "Sharpstown: Seasoned Together"
- 2 "Unity / Paths Forward"
- 3 "Bold Dreams, Brave Hearts"
- 4 "A Book Is A Rocketship"



*Farewell to one of
Sharpstown's Champions...
(Tribute Inside)*



**Mark Your
Calendars!**

State Primaries
March 3, 2026

Introducing

OUR ASSOCIATE MEMBERS



**Alice Lee,
Community
Supporter**



Braescroft Animal Clinic

Patronizing these businesses and organizations shows appreciation for Associate Members who contribute financially in support of SCA programs and activities.

Become an Associate Member!

Do you love Sharpstown but don't live within our official boundaries? Have a business in or near Sharpstown? You can still be part of the community! The Sharpstown Civic Association offers Associate Memberships for those who want to stay connected, support our efforts, and participate in events and initiatives that make our neighborhood thrive.

As an Associate Member, your organization will receive:

- Recognition in the SCAN, our printed newsletter delivered to over 6,600 households in Sharpstown.
- A listing in our monthly email update, reaching our many active residents.

Join us as an Associate Member and help keep Sharpstown strong, safe, and welcoming for all!

For more information or to sign up, visit SharpstownCivic.org

Pictured here: Ribbon-Cutting Ceremony on January 30th at SPARKX Logistics.

Mural Locations:

Gulfton: Paths Forward

Gulfton Unity

Sparx logistics (5630 Renwick Dr, Houston, TX 77081) along Glenmont (west of Renwick)

Music and Culture

Sharpstown: Seasoned Together

Our Roots, Our Future

Atrium Cellini (6303 Gulfton St, Houston, TX 77081) along Westward (south of Gulfton)

Bold Dreams, Brave Hearts

A Book Is A Rocketship

Étoile Academy (6648 Hornwood Dr, Houston, TX 77074)

Garden of Alebrije Dreams

Harris Health Vallbona Clinic (6630 De Moss Dr, Houston, TX 77074) along Tarnef (south of Hornwood)



BOARD OF DIRECTORS

President



Elizabeth Bagby Schooler, Sec 2
scaboard.schooler@gmail.com
713-550-3351 (cell)

Vice President



Lee Sharp, CCT 2
Lee@LeeWSharp.com
346-704-4099 (cell)

Treasurer



Sharon Galloway, CCT 2
shgallow@yahoo.com
713-988-6653 (cell)

Secretary



Matthew Cowan, CCT 3
wrcowan1@hal-pc.org
713-818-3114 (cell)



Thomas Ansah, CCT 2
thomasansah25@gmail.com
713-751-9094 (cell)



Mark Alan Harrison, Sec 1
mrkain1@aol.com
713-418-0481 (cell)



Debra Calkins, Sec 2
dkcalkins52@gmail.com
713-774-4705 (cell)



Kathy Holston, CCT 3
holston.kathy@gmail.com
832-845-8476 (cell)



Greg Degeyter, CCT2
greg@degeyterlaw.com
713-505-0524 (cell)



Carol Sotier, CCT 3
carolsotier@sbcglobal.net
713-825-2808 (cell)



Donna Fain, CCT 3
sca.fain@gmail.com
713-818-9931 (cell)



Anne Wilburn, Sec 1
anneffa4ever@gmail.com
713-988-8969 (cell)

TABLE OF CONTENTS

Membership	4-6
Crime Report(s)	7
Important Phone #'s	8
Community Happenings	9-12
District J's Corner & 4 The Record	13
Education	14
Deed Restrictions	15
Crossword Puzzle	16
Trash & Recycling	17
How To Advertise	19

SCA OFFICE

Operations Manager: Scott Gilbert
Scott@SharpstownCivic.org

Office Assistant: Becky Childers

Office Hours

Mon-Fri, 9AM-4PM
Phone: 713-789-2311
Fax: 713-789-2312

Physical Address: 6815 Redding Rd
Houston, TX 77036
Mailing Address: PO Box 36559
Houston, TX 77236-6559

SCA Mission Statement

"To serve and improve the Sharpstown community through enforcement of deed restrictions, architectural controls, enhancing our residents' safety, and promoting Sharpstown as one of Houston's most desirable neighborhoods."

ON THE COVER

Commissioner Lesley Briones is proud to introduce a new collection of public art celebrating the resilience and diversity of Gulfton, Sharpstown, and Alief.

These high-impact murals aren't just paintings; they are cultural landmarks. By transforming ordinary streets into canvases, we ensure that the paths between us honor the diversity and heritage of the people who travel them every day. *(Photo Credit/Harris County Precinct 4 photographers)*



FROM THE PRESIDENT'S DESK

Foundation of Leadership: TRANSPARENCY

- T** – Trust: Building confidence through honesty and openness.
- R** – Respect: Valuing every neighbor’s voice and perspective.
- A** – Accountability: Taking responsibility for actions and decisions.
- N** – Neutrality: Leading fairly, without bias or favoritism.
- S** – Sincerity: Acting with genuine care for the community.
- P** – Partnership: Working together toward shared goals.
- A** – Authenticity: Staying true to values and commitments.
- R** – Responsibility: Serving with integrity and dedication.
- E** – Ethics: Upholding strong moral principles in every decision.
- N** – Nobility: Leading with dignity and purpose.
- C** – Clarity: Communicating openly and effectively.
- Y** – Yield (to truth): Embracing honesty, even when it’s difficult.

TRANSPARENCY is not just a word—it’s the guiding principle for every action, decision, and conversation in this first year of leadership.

Join me in keeping our neighborhood, Sharpstown, moving forward.

Respectfully yours,

Elizabeth

Elizabeth Bagby Schooler, President

ALERT!

Paid members benefits... did you know?

Member Perks

MONTHLY MEMBERSHIP MEETINGS SPECIAL DRAWING - PAID Members enjoy the opportunity to win a special prize at the end of the meeting. This past year we gave away family memberships to the Houston Museum of Natural Science and the Houston Interactive Aquarium & Animal Preserve, and many other cool gifts.

VACATION WATCH - Did you know that one important service for PAID Members is a complimentary vacation watch for your home provided by S.E.A.L. Security?

NOTARY SERVICE - Basic services at the SCA office. See Scott.

SHRED DAY - Plans to restart this program for paid members are in the works.

SPECIAL EVENTS - Members Only Dinners, Movie Nights, NEW Home Maintenance and Repair Workshop, and more!

Simply download and complete the form on our website, then call 713-338-2266, the dedicated Sharpstown S.E.A.L. hotline. An officer will check on your home daily to help make this year's vacation a relaxing getaway.

Get all the details by visiting www.sharpstowncivic.org

Sharpstown Civic Association 2026 Membership Dues



**Sharpstown is more than just houses
– it's our community, our home.**

2026 Dues \$280

Your membership dues are an investment in the safety and vibrancy of Sharpstown. The Sharpstown Civic Association (SCA) relies on volunteers, your fellow homeowners, who dedicate their time to protecting property values, enforcing deed restrictions, and enhancing our neighborhood's beauty.

Last year, only 1,166 out of 6,680 homes (17.4%) supported the SCA. Without proper funding, vital services like S.E.A.L. Security patrols, mosquito spraying, deed restriction enforcement, and the SCAN Newsletter are at risk.

Let's reverse this trend! Join your neighbors and become a dues-paying member today.

Services Your Dues Provide:

- SEAL Security Patrols
- Deed Restriction Enforcement
- Architectural Control
- SCAN Newsletter

Member Benefits:

- Free Notary Services
- Free SEAL Vacation Watch Free
- Members Only Lunch/Dinner
- Raffle Drawings at General Meetings
- Pride in protecting your home and community

To be an SCA voting member, a minimum of \$90 is required.

Payments may be divided into portions, contact SCA office if needed.



YOU MAY JOIN OR RENEW ONLINE AT SHARPSTOWNCIVIC.ORG

or please return this form with your payment - Thank you!

2026 Membership Dues Request is \$280.00



Name(s) _____ Phone _____

Address _____ Zip Code _____

Credit Card # _____ Exp Date ____ / ____ CVC _____

VISA Master Card Discover

Check # _____ Amt Paid \$ Email _____

(Check here) I consent to received Periodic Community updated to this email.

Signature _____ Date _____

One payment of \$280.00 is requested. Please contact the SCA office if other payment arrangements are needed.
To be a member, a minimum of \$90.00 is required.

General Membership Meeting HIGHLIGHTS, , January 22, 2026



Sharpstown High School JROTC posted the colors. We are always so appreciative of their participation in our meetings.



Ivan Sanchez is part of a group called **Together for Texas**, which is conducting a blanket drive ahead of the upcoming winter storm.



Director Donna Fain wowed us with titillating Trivia Questions about HCC and the Rodeo.

Dr. Michael Webster, President of the Houston City College Southwest Campus

- Numerous Certifications and programs offered to incoming students, including 911 Emergency Dispatch, HVAC, Welding, and Cyber Security
- The AI and Robotics program has won the *AI Global Impact Festival* for the past 4 years, and recently won the *NASA Gateway Blue Sky* contest using AI-powered drones to locate feral hogs on ranches, a significant problem in Texas.
- The Stafford campus prepped 48 welding students for two weeks at SpaceX's request. They were tested; all 48 passed, and SpaceX hired six to work on their project!



Lauren Taylor, HLSR Speakers Committee member, shared what she and her team do... go to area schools and talk about the Rodeo, teach line dances, practice roping (like she did before the meeting began), and much more. Let's Rodeo y'all!



SHS coach and student assist with putting up tables after the meeting.



CM Ed Pollard discussed issues with heavy trash pickup and what we can do as members of the community. Do not add to your existing pile of heavy trash at your curb, as there is a limit! The SW Depository is a great option, right down the road at 10785 SWFRY, and is open 10-6, Wednesday-Sunday.

Alice Lee, Precinct 4 Chief of Staff, informed us that Bayland will open as a warming center for our area due to impending inclement weather. The American Red Cross will be on hand to assist participants. All are welcome, including pets.

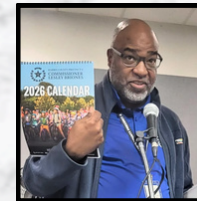

Brian Pendleton, Precinct 4 Community Engagement Coordinator, showed off the new 2026 County calendar.



What do you do when your children are expecting snow as Arctic weather approaches? Why, make it snow of course, or at least make lots of icicles! How fun is that!!!

Photos submitted by Greg Degeyer

SHARPSTOWN HOMES CRIME REPORT

SHARPSTOWN HOMES CRIME REPORT December 2025/January 2026										
TYPE OF CRIME	SECTION									TOTAL
	S1	S2	S3	S5	T1	T2	T3	CCEE	CCEW	
Aggravated Assault	0	0	0	0	0	0	0	0	2	2
Burglary	1	2	0	0	0	0	0	0	0	3
Murder	0	0	0	0	0	0	0	0	0	0
Property	2	2	1	1	0	0	0	0	1	7
Rape	0	0	0	0	0	0	0	0	0	0
Robbery	0	0	0	0	0	0	0	0	1	1
Theft	1	3	1	0	1	2	6	0	1	15
TOTAL	4	7	2	1	1	2	6	0	5	28

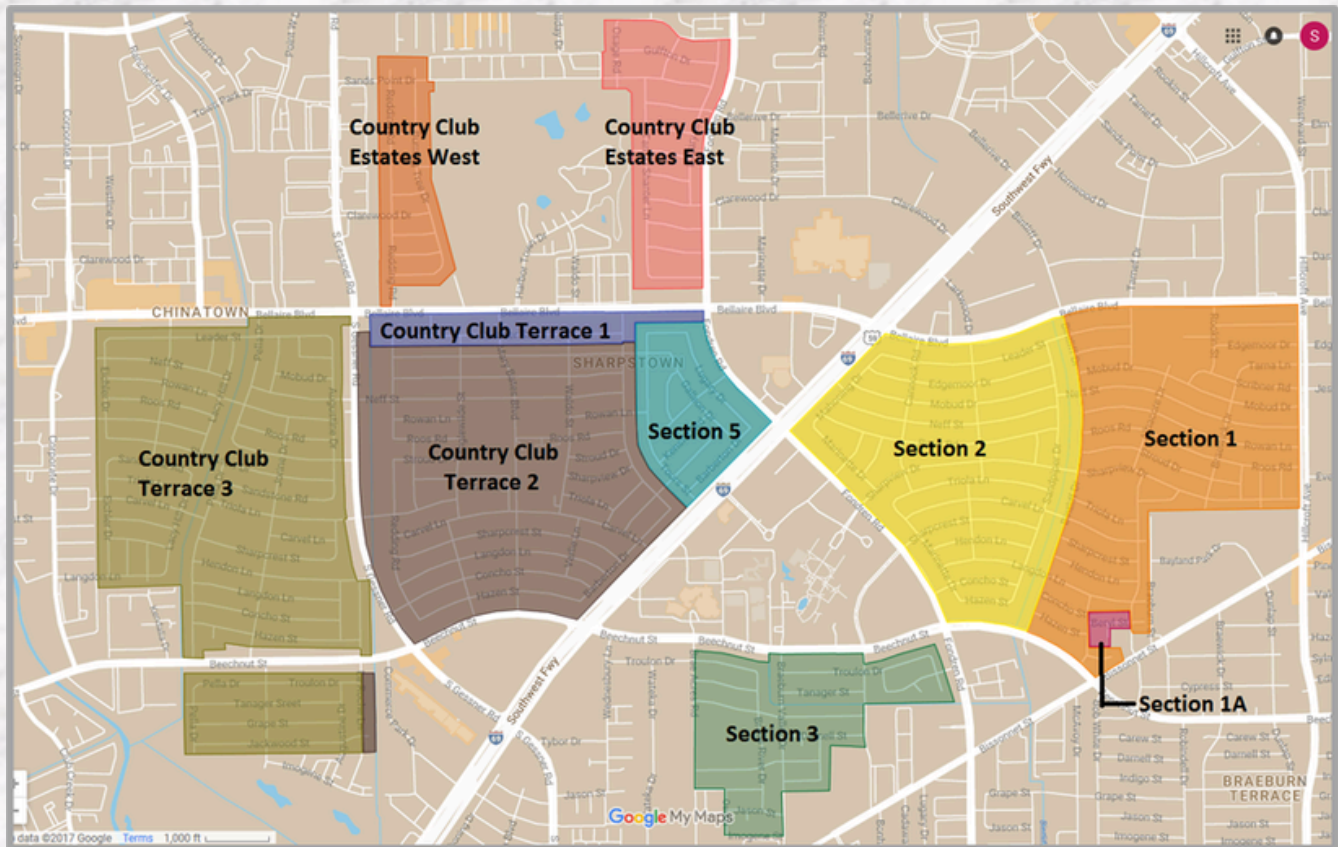

Definitions of Crime Types

Aggravated Assault - an attempt to cause serious bodily injury purposely.

Burglary - (breaking and entering) an unlawful entry into a building for the purpose of committing an offence. Usually, that offence is theft.

Property Crime - destruction, damage, vandalism

Rape - unlawful sexual activity carried out against the will of a male, female, or person under age, or incapable of consent.

Robbery - the taking of money or goods in the possession of another, from his or her person or immediate presence, by force or intimidation.

Theft - the act of stealing; the wrongful taking and carrying away of the personal good or property of another; larceny,. Examples include ransacking unlocked cars, taking property out of open garage doors, taking a purse off a front seat of an unlocked car, taking a mower out of the back of a pickup truck.



Looking for HPD in All the Right Places



Need a copy of an accident report? Want to talk to an officer about a problem in your area? You see something suspicious and want to let Law Enforcement know about it?

In Sharpstown, you won't have to go very far. Our community is served by two HPD substations, South Gessner and Midwest, and two HPD storefronts, Gulfton and Ranchester. The officers located at these facilities are there to help you in any way they can, so give them a call or a visit if you need assistance.

Sharpstown Area HPD Substations

Midwest 24 hours daily 832-394-1200 7277 Regency Square	South Gessner 24 hours daily 832-394-4700 8605 Westplace Dr.
---	--

Gulfton Storefront
8am-4pm M-F
832-394-2660
6227 Southwest Fwy



Important Contacts

SCA Office	713-789-2311
S.E.A.L. Security 24 Hrs	713-338-2266
Department of Public Safety (DPS) <i>Including non-emergency roadside assistance, answered 24 hours a day</i>	800-525-5555
Harris County Sheriff's Office <i>Non-Emergency Line</i>	713-221-6000
Directory Assistance <i>White/Yellow Pages</i>	411
United States Coast Guard <i>Coast Guard Air Station/Houston</i>	713-578-3000
Center Point Energy	713-659-2111
National Emergency Child Locator Center	866-908-9570
Disaster Distress Hotline	800-985-5990
CM Edward Pollard <i>COH-District J Office</i>	832-393-3015
Rep. Gene Wu <i>Texas House – District 137</i>	713-271-3900
Rep. Lauren Ashley Simmons <i>Texas House – District 146</i>	512-463-0518
Sen. Borris Miles <i>Texas Senate – District 13</i>	512-463-0113
City of Houston Service Helpline	311
Harris County Appraisal District <i>Property Search</i>	http://hcad.org
Southwest Management District	281-674-9194
State Bar of Texas Legal Hotline	800-504-7030

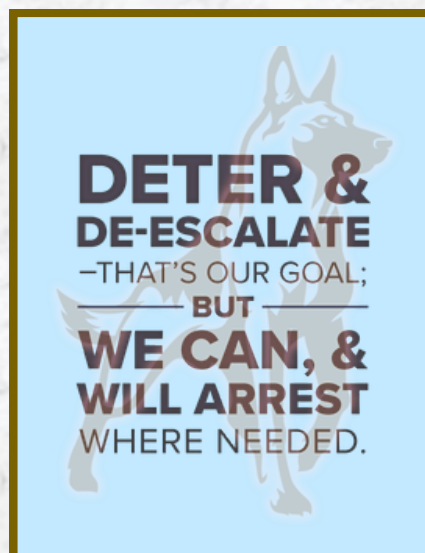

Restaurants you need to *visit!*

I know my neighbors enjoy a good breakfast, but I don't know how many have tried Taiwanese breakfast. If you would like to give it a try, I highly recommend **Six Ping Teamenjoin, 9384 Bellaire Blvd.** My sons and I went there on New Year's Day for our 1st meal of 2026.

We shared the sesame pancake with egg, the fried yin si juan served with sweetened condensed milk and hot soy milk with youtiao. The last being one of my favorite breakfast combinations.

We saw that they also offered lunch items and couldn't resist turning breakfast into brunch. My younger son who tries to avoid meat ordered the sesame spicy dry noodle. My older son who loves spicy food ordered the mapo tofu dry noodle. I had one bite of it and immediately felt the mala from the Sichuan peppercorn. Of course, I had to try the iconic Taiwanese meal of braised pork rice (lu rou fan) - basically bacon, egg and rice.



M. Wong

Do you have a favorite Sharpstown area place to eat, enjoy a yummy dessert, or vist with a neighbor over a good cup of coffee? Please share with us! There are so many hidden gems here in our neck of the woods and we would thoroughly enjoy hearing from you.

Drop a line or two and maybe a photo to scaboard.schooler@gmail.com :)

PX Cafe hosted a PopUp Collab recently. Check out some of the highlights!



Drop in sometime soon and experience this gem right here in our little corner of the city!

Photos by Ericka Haley



The **Eat Drink HTX** menu list is out and it includes **Sharpstown's own PX Project + Cafe!** This is such a fantastic opportunity to check them out and support a good cause at the same time!

<https://houstonrestaurantweeks.com/restaurants/edhtx-2026-february/px-project-cafe/>

2025-2026 UIL RECLASSIFICATION AND REALIGNMENT

HOUSTON ISD ATHLETICS

10-5A (FOOTBALL, VOLLEYBALL, BASKETBALL)

- Chavez**
- Galena Park** – (VB and BB only- not football)
- Houston**
- Madison**
- Milby**
- North Brook**
- Sharpstown**
- Waltrip**
- Westbury**
- Wisdom**

Library News

Walter Branch Library...
So Much More Than Books

Our neighborhood library offers an outstanding calendar of programs and classes such as:

- Basic, intermediate and advanced computer applications like Word, Excel, and PowerPoint
- Family movie time
- Bi-lingual story hours in Spanish and Mandarin
- Citizenship classes
- Find the full calendar of events, plus location and hours at

http://houstonlibrary.org/location/walter-neighborhood-library?items_per_page=200#events

In Loving Memory of Dale Ada Davidson

October 9, 1958 - January 3, 2026

Dale Davidson, age 67, passed away peacefully on January 3, 2026, in Houston, Texas, after a courageous battle with appendix cancer.

A service celebrating Dale's life and Christian faith will be held at Westbury Baptist Church on February 21, 2026, at 2:00 PM.

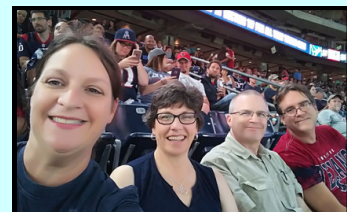
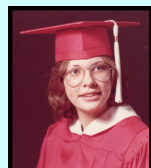
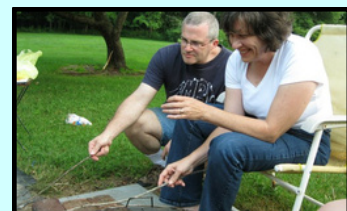
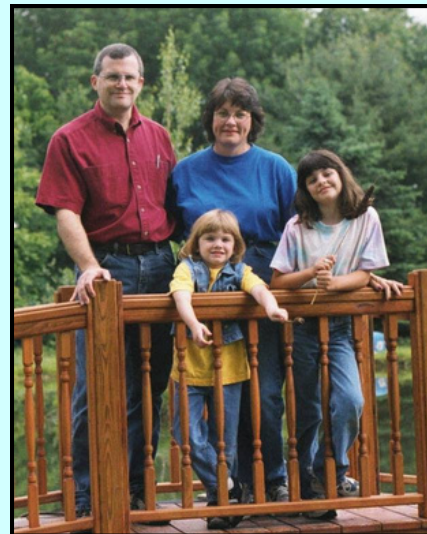

Dale was always supportive of the District J office and could be counted on for wise counsel and thoughtful insight on ways to improve the quality of life for residents of Sharpstown. Her laugh was infectious and she always showed up to put in her sweat equity. My office offers our sincere condolences to her family on their loss. May God continue to comfort them, and may we all remember Dale for the wonderful person she was.

CM Edward Pollard

Words to describe Dale:

- Devout Christian
- Dedicated Wife
- Loving Mom
- “Gandy”
- Fierce Friend
- Listener
- Musician
- Warm-hearted
- Volunteer
- Bunco Player
- Studios
- Adventurer
- Gregarious
- Texans Fan





When our oldest started middle school, we searched for a church where she'd have friends from both school and church. Visiting Westbury Baptist, our daughter instantly recognized Amy Davidson from her science class. Amy's mother, Dale, greeted us and taught our adult class—I knew we were home. Our daughter had a friend, and so did I. Only God knew how meaningful that friendship with Dale would become. Dale knew everyone, and her smile and laugh were unforgettable. I miss that laugh dearly.



Dale also lived in Sharpstown, my lifelong neighborhood. She loved it as much as I did, and her community involvement brought us even closer. When our girls graduated, we and other Sharpstown moms, like Carol Sotier, started a neighborhood Bunco group that's met for 11 years. Each month, Dale shared the latest Sharpstown news. I often wished my parents could have heard her insights. We've lost a true friend and advocate in Dale.

Sandra Cunningham



(For we walk by faith, not by sight.)
2 Corinthians 5:7

In May 2014, my youngest graduated high school, and I faced an empty nest. Though I'd lived in Sharpstown CCT 3 since 1980, I wasn't involved in the neighborhood or connected with many people. That changed when I met Dale in July 2014. She welcomed me, introduced me to neighbors, and together we started a Bunco group and a walking group—both still active. Dale encouraged me to join civic meetings, and now I'm a board member, surrounded by friends and a strong community.



Dale's friendship changed my life. Her memory is a treasure, and I will miss her always.

Carol Sotier



Dale was a person who truly lived into her faith every day, and she made our world a better place. Her joy and commitment to serving her fellow humans were compelling and inspiring. Her legacy is eternal.

Pat Menville



Placing Your Cart

HOW TO POSITION YOUR CARTS CORRECTLY

1 Allow 3 feet between carts and structures such as mail boxes, lamp posts and 5 feet from cars

2 Face the metal bar toward the street

3 Make sure the lid is closed

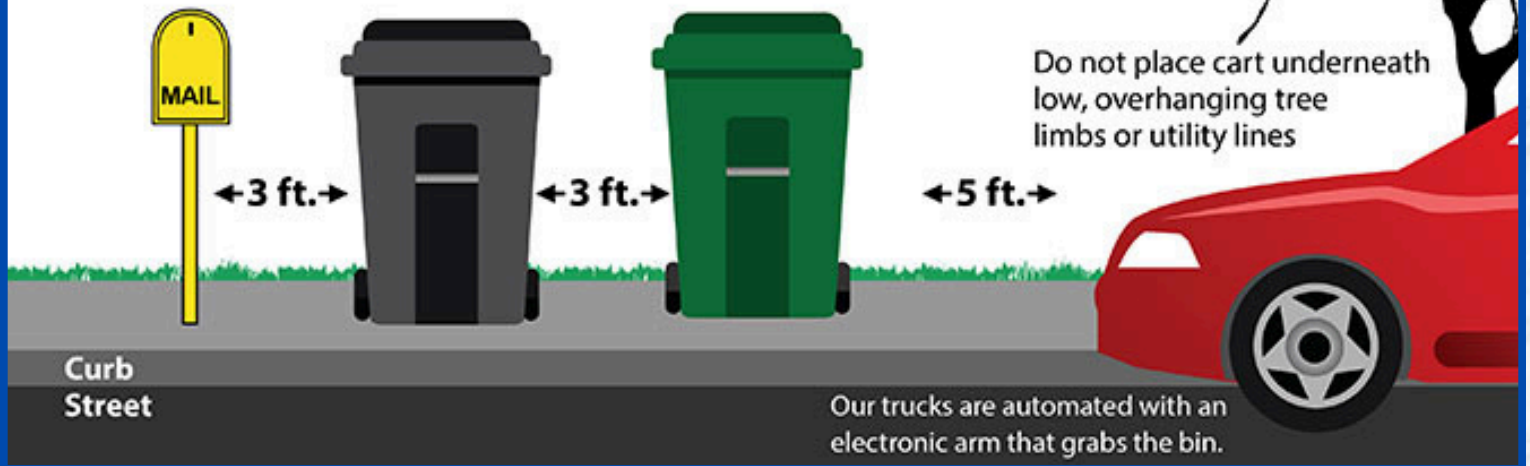

Garbage Containers & More

- Garbage containers must be placed at the curb by 6 a.m. with the handle facing the house.
- There must be at least 3 feet of space between garbage and recycling containers.
- Containers must be accessible and not blocked by obstacles, including parked cars, trees, mailboxes, fencing, etc.
- Extra bags of garbage are collected only if they have a special tag attached. These tags may be purchased at HEB and participating Kroger stores.
- A second or third garbage container will be serviced for a monthly fee that is added to your water bill. Call 311 to enroll in "Add-A-Can."

SHARPSTOWN PLUMBING CO.

Residential Service & Repair
Est. 1971

Dennis Hensley
Owner/Master Plumber

RMP 16276

713-771-2608

Call Anytime

SCAM ALERT

Scammers are impersonating government employees. They may threaten you and may demand immediate payment to avoid arrest or other legal action. Do not be fooled!

If you receive a suspicious call:

1. HANG UP!
2. DO NOT GIVE THEM MONEY OR PERSONAL INFORMATION!
3. REPORT THE SCAM AT OIG.SSA.GOV

J City Deploys Private Heavy Trash Pickup Program

After more than a year and a half of disruptions to City of Houston solid waste services, J City is once again deploying its private heavy trash pickup program to help address ongoing resident frustration with delayed heavy trash and tree waste collection.

While citywide service challenges continue, J City is taking proactive steps to support cleaner neighborhoods. J City is currently the only council district with both a dedicated Beautification Team and a private heavy trash program, underscoring its commitment to maintaining safe and attractive communities.



The private heavy trash program is intended to supplement City services and provide targeted relief in areas most impacted by service delays. Residents should note that up to eight cubic yards of waste will be collected per address (approximately the size of the back of a pickup truck). Any materials exceeding that amount are the responsibility of the resident and will not be collected. Residents who hire contractors for home repairs, renovations, or tree work must also ensure that all debris is properly hauled away by those contractors.

Through this program, J City aims to reduce curbside blight and improve neighborhood conditions while city services continue to recover.

*Together we will,
Councilman Edward Pollard*



HARRIS COUNTY PRECINCT 4
COMMISSIONER
LESLEY BRIONES

EGG HUNTS ● EASTER BUNNY ● FOOD TRUCKS
CRAFTS & GAMES ● ALL AGES DJ

Easter Egg Hunt

Saturday, March 28 | 10 a.m. - 2 p.m.

Bayland Park, 6400 Bissonnet Street, Houston, TX 77074



**PRE-REGISTER HERE:
hcp4.info/egghunt-26-ad**



After School Sharpstown HS Campus Clean-Up



On Friday, January 16th over thirty students in Sharpstown High School's student council and civic engagement club participated in an after-school campus clean-up. The 70-degree weather made for a perfect afternoon, and the students were conscientious about picking up as much litter as possible before sunset. Thank you to teacher sponsors Jared Duplechain and Arnolia Robinson for encouraging students to get involved in this important activity.

Article Submitted By: Joyce Akins



**“Bobby Plummer
Trench Boss Award”
WINNER!!!**



Associate Head Coach Wynton Perro, Elizabeth Plummer, “Bobby Plummer Trench Boss Award” winner Kaliss Johnson, Terry Plummer Derner, Head Coach Tre’ Perro (Johnson is a Junior Center)

**BERKSHIRE
HATHAWAY** | PREMIER
HOMESERVICES | PROPERTIES

COMMERCIAL DIVISION

Greg Shaw

COMMERCIAL DIVISION

1505 Heights Blvd.
Houston, Texas 77008

Office: 713-862-0000

Cell: 713-201-3748

greg.shaw@preproperties.com

A member of the franchise system of B&H Affiliates, LLC

Architectural Fee Schedule

Below are the fees charged for review of exterior changes to your home. These are the more commonly received requests and account for the costs involved in plan review. This fee schedule, along with the Architectural Change Request, can be found on our website sharpstowncivic.org

Roof	\$25		Addition to House	\$250		Paint Siding	\$25		Outbuilding/Shed	\$50
Fence	\$25		Generators / Solar Panels	\$25		Garage Doors	\$25		Patio / Patio Roof	\$50
Windows	\$25		Driveway Alterations	\$100		Pool	\$100		Garage Conversion	\$50
Gutters	\$25					Carport	\$100			

**Be sure to submit your Architectural Approval Form/Fee to the SCA Office
P R I O R
to making exterior changes to your home or property!**

- Getting a new roof?
- Installing new windows?
- Building a new fence?
- Does your house need to be painted?
- Making changes to the driveway?
- Installing/building a new shed?
- Plans to convert your garage?
- Installing solar panels?

Go to the following web link to get more information:

sharpstowncivic.org/committees/architecture-committee/acc_request_form/



Extra Sheets, Blankets, Newspapers?

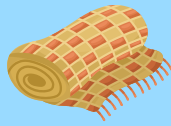

If you have any blankets, comforters, towels, pillowcases, sheets, or old newspapers to donate, please contact Martha Vasquez. She will deliver these much-needed items to area rescues during this time of year.

The animals do not care about the condition of these items; they just need them to stay warm. Please share your old newspapers as well!



Martha can pick up any items, no matter how small. All is appreciated. Contact her to arrange pickup. Get in touch with *Martha Vasquez* on Facebook!



FIREWORKS ARE ILLEGAL

The use of fireworks are not only illegal in the City and parts of the County but they are also are very dangerous.

It is illegal to discharge fireworks the City of Houston. A Texas House Bill allows for the transportation of fireworks, however there are restrictions including where the fireworks are located inside the vehicle and if they are opened or unopened.

The City will continue to enforce, in compliance with state law, fire and safety regulations within the city. Harris County residents should also be aware that HFD will be enforcing the fireworks ban in the Limited Purpose Annexation Areas.

The fines are anywhere from \$500 - \$2000 for each individual firework. *Full article may be found at <https://www.houstontx.gov/fire/safetyinfo/fireworks.html>*

A complex of three Little Free Libraries sprouted in Bayland Park last year.

Find some bookish clues in the puzzle today!

ACROSS

- 1 Popular 90's-era BBC sitcom, short.
- 6 Gastropods with little or no shell
- 11 Composure, mien
- 12 Latin for ground, often described as firma
- 13 "Well, I'll be a monkey's _____!"
- 14 All drivers 18-84 years old must do this with their license every 6 years
- 15 Hangs from a graduation cap
- 17 Area formed by the tibia
- 19 Riches
- 23 Oldest operating subscription TV service in US
- 24 Cool, or your coxa
- 25 Process taking a company public, abbr.
- 26 Orion the _____
- 28 Three tsp.
- 29 Local library branch
- 31 To point to
- 34 Unsuitable, inappropriate
- 37 Eight musicians
- 38 Los Tigres del _____ broke rodeo paid ticket record in 2024
- 39 Woodpecker living from Alaska to Florida
- 40 Romantic rendezvous

DOWN

- 1 Controversial Simpsons store owner
- 2 Word often preceding *appétit*
- 3 Harry Potter appears in this category of books
- 4 Lion in the Narnia series
- 5 Not all of these sting
- 6 Silkwood star
- 7 Houston-based R&B singer _____ James
- 8 Ashy container
- 9 Popular admissions exam
- 10 Past tense of "to see"
- 16 Froyo combo
- 17 You might hear this if you're too loud at the library
- 18 Local university, formerly
- 20 Building located at the corner of Fondren & Clarewood
- 21 Report in Mike Judge's Office Space
- 22 To travel bunny-style
- 24 Filling, satisfying
- 27 Category for those 8 to 12 years old
- 28 Highest male chest-voice type

SHARPSTOWN CROSSWORD

Submitted /Created by Sharpstown Neighbor, Joyce Cyanocitta

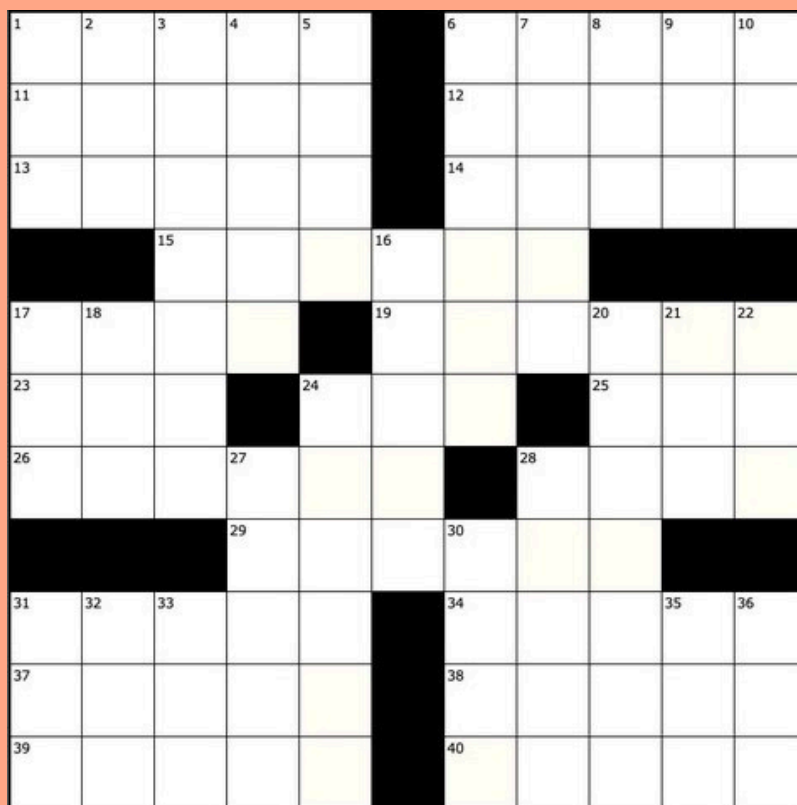

DOWN, continued

- 30 If this is too dark, you may fail your car inspection
- 31 Of bamboo or fiberglass, used for fishing
- 32 Combining form meaning habitat or environment
- 33 Internet slang showing approval
- 35 In medical abbreviations, p3atients
- 36 Offensive was one of the largest campaigns of the Vietnam War

Answer Key on Page 19



HPARD
HOUSTON PARKS
AND RECREATION DEPARTMENT
A CAPRA Accredited Agency

**Lansdale Park
Activities**

Free After School Program for children ages, 6-13)

Seeking Adult * Teen Volunteers
(build your own hours)

Lansdale Community Center
Isis Thomas, Site Manager
8201 Roos Rd
Office: 813-272-3668

Please visit our website for program registration:
<http://www.houstontx.gov/parks/communitycenters/cc-lansdale.html>

WEEKLY TRASH PICKUP

Sec 1, 2, 3, 5 and CCT1, CCT2, CCT3 are "TUE-B"
 Estates East and West are "MON-A"

HEAVY TRASH SCHEDULE

Month	MON	TUE	Collection
MAR	9 ???	10	Tree Waste Only (delayed)
APR	13 ?	14	Junk Waste Only (delayed)

Sections 1 & 2 - Heavy Trash on TUE
 (2nd TUE of every month)

Sections 3, 5, CCT1, CCT2, CCT3, Estates East & West
 Heavy Trash on MON
 (2nd MON of every month)

**Yard Waste or Grass Clippings
 are picked up on WED. (delayed) ???**

You may place Heavy Trash waste at the curb no earlier
 than 6 PM on the FRI before collection.

http://www.houstontx.gov/solidwaste/service_schedules.html

Heavy Trash Defined - Under Proper Operating Circumstances

"Tree Waste" is defined as "clean" wood waste such as tree limbs, branches, and stumps. *Lumber, furniture, and treated wood will NOT be accepted.*

Junk Waste may NOT be placed for collection during a Tree Waste month.

Tree Waste months are January, March, May, July, September, and November.

"Junk Waste" is defined as items such as furniture, appliances, and other bulky material.

Tree Waste is accepted during Junk Waste Months; *however*, to ensure your Tree Waste is recycled, you may hold your tree waste materials until the next Tree Waste month or take it to a Neighborhood Depository/Recycling Center.

Junk Waste months are February, April, June, August, October and December.

Residents who wish to dispose of Tree Waste

or Junk Waste before their scheduled once-per-month collection may use one of six Neighborhood Depository & Recycling Centers. The closest location to Sharpstown is 10785 Southwest Freeway, Houston, TX 77074. They are open Wednesday to Sunday 10:00 am - 6:00 pm, and their phone number is (713) 541-1953.

Restrictions:

- No more than 8 cubic yards (about the size of a minivan) of heavy trash may be set out.
- Up to 4 cubic yards of building material (excluding shingles, brick, plaster, or concrete) may be collected if generated by the resident.
- Contractor-generated material (tree removal, construction, roofing, remodeling, etc.) **will not be collected.**

Contractors are responsible for removing their debris.

- If authorized and unauthorized items are mixed, the entire pile **may** be refused.
- Collection services are not available to multi-residential structures with more than eight units.

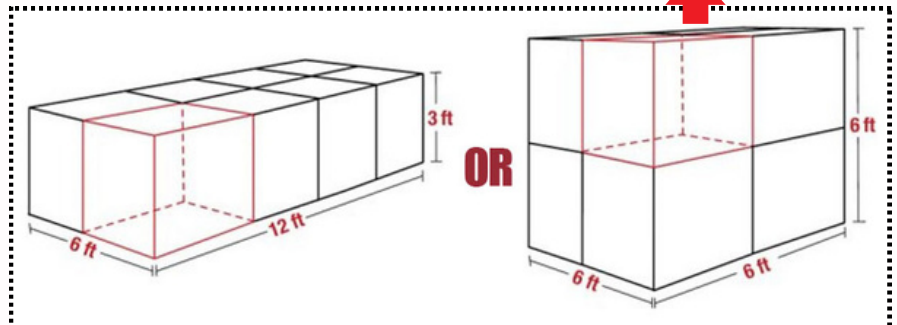

Warming Centers Open Up

The Southwest Multi-Service Center on High Star Drive operates as one of many area-designated warming centers during extreme cold weather events in Houston. It provides a safe, warm space and often opens in coordination with other city locations to help residents stay warm.

Bayland Community Center operated as a Warming Center for individuals, including pets, in need of shelter during the recent Arctic weather in January. Hot meals, blankets, a place to sleep, as well as medical care was provided to many in our community.

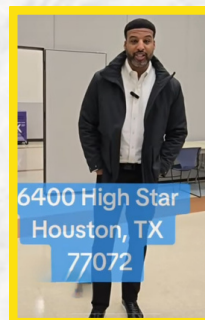
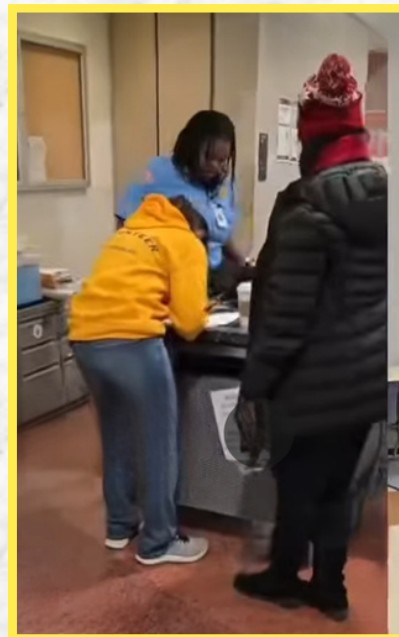

★ HOLIDAY FLAG PROGRAM ★

The Rotary Club of Sharpstown and the Sharpstown Civic Association are partnering to beautify Sharpstown during (4) Holidays per year!

- Memorial Day
- Independence Day
- Labor Day through 9/11
- Veterans Day
- May
- July
- September
- November

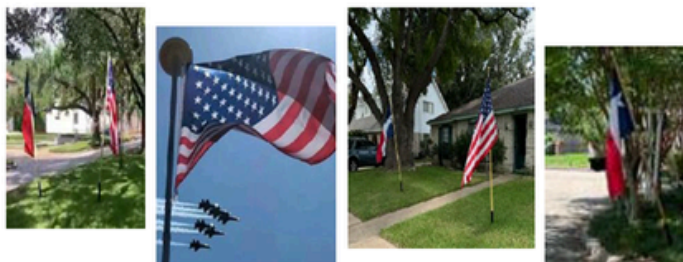

Order your Subscription on our secure website
www.FlagsForSharpstown.org

★ Annual Subscription are \$80 per flag ★

Based in Sharpstown, our Club celebrates the diversity of the Houston Community!



Find our more at: <https://portal.clubrunner.ca/3953>





**DISABILITY
HELP
HOUSTON**

Greg Degeyer

9898 Bissonnet Suite 626 Houston, TX 77036
 (713) 485-0610 Main Line
 (713) 505-0542 Cell
degeyerlaw@gmail.com
degeyerlawintake@gmail.com Intake E-mail

Free Estimates



GOMEZ REE'S
Landscaping L.L.P.

Trees-Landscaping-Irrigation
Bonded and Insured,
Commercial and Residential
30+ years of experience
713-779-7511
gomeztreesandlandscaping.net

WE CAN HELP

- Missing Shingles?
- Have Leaks?
- Turned Down by Insurance?

FREE ROOF INSPECTIONS



LEGACY ROOFING & EXTERIORS

YOUR WIND AND HAIL STORM CLAIMS SPECIALIST

CALL TODAY!
281-990-3037
 legacyroofers@gmail.com

WWW.LEGACYROOFER.COM



Answer Key - How did you do?

1	A	B	F	A	B	6	S	L	U	G	S		
11	P	O	I	S	E	12	T	E	R	R	A		
13	U	N	C	L	E	14	R	E	N	E	W		
15	T	A	S	S	E	L							
17	S	H	I	N		19	W	E	A	L	T	H	
23	H	B	O		24	H	I	P		25	I	P	O
26	H	U	N	T	E	R			28	T	B	S	P
29			W	A	L	T	E	R					
31	R	E	F	E	R	34	I	N	A	P	T		
37	O	C	T	E	T	38	N	O	R	T	E		
39	D	O	W	N	Y	40	T	R	Y	S	T		

How To Advertise in The SCAN

The SCAN (Sharpstown Civic Association Newsletter) in the official publication of Sharpstown Civic Association Inc., a 501c4 organization. Pricing, deadlines, and more is available on our website... SharpstownCivic.org



Contact: Scott Gilbert, Operations Manager
 SCA Office
 6815 Redding Road
 Houston, TX 77036

Phone: 713-789-2311 Fax: 713-789-2312
E-mail: Scott@SharpstownCivic.org

Editors: SCAN Committee
E-mail: scaboard.schooler@gmail.com

This newsletter is published bimonthly by the Sharpstown Civic Association.



6815 Redding Road
P.O. Box 36559
Houston, TX 77036



A DEED RESTRICTED COMMUNITY

Check out SharpstownCivic.org
or "like" us on FACEBOOK



Membership Meeting Schedule

We meet in person on the 4th Thursday of the month (with few exceptions); our meeting streaming LIVE on our Facebook page.

Meet and Greet @6:30 PM
Meeting starts @7:00 PM

February 26, 2026
Yard & Garden Prep | Trees

March 26, 2026
Memorial Hermann
Please join us! We are excited to meet YOU.

Bayland Park Community Center
6400 Bissonnet

LULU LIQUOR

7710 BELLAIRE BLVD. SUITE S HOUSTON TEXAS, 77036
FAMILY OWNED & OPERATED
CALL US AT 713-270-5347

MAKING CUSTOMERS HAPPY FOR 25 YEARS!
SUMMER'S HERE—SPREAD THE CHEER WITH LULU LIQUOR NEAR!